

## Bevel gear

stepless  
height adjustment

3 0 1 0

3 0 1 1

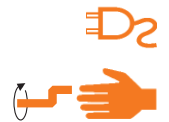

### Description:

Gear for stepless height adjustment, mainly for manual sit/sit work stations.

### Special features:

- Ratio 1 : 1 or 1,33 : 1
- Glass fibre reinforced plastic housing
- Hardened steel gear cogs
- 1200 N load
- Output spindle for push force only

### Customer specific:

Because of the modular design it is possible to meet special customer requirements even for small quantities.

The gear is available in various lengths and with various mounting brackets.

Up to 4 input wheels are possible. The gear can be also driven from above.

### Caution:

Please take into account that depending on the spindle pitch, the system could back-drive.

# Bevel gear 3010/3011

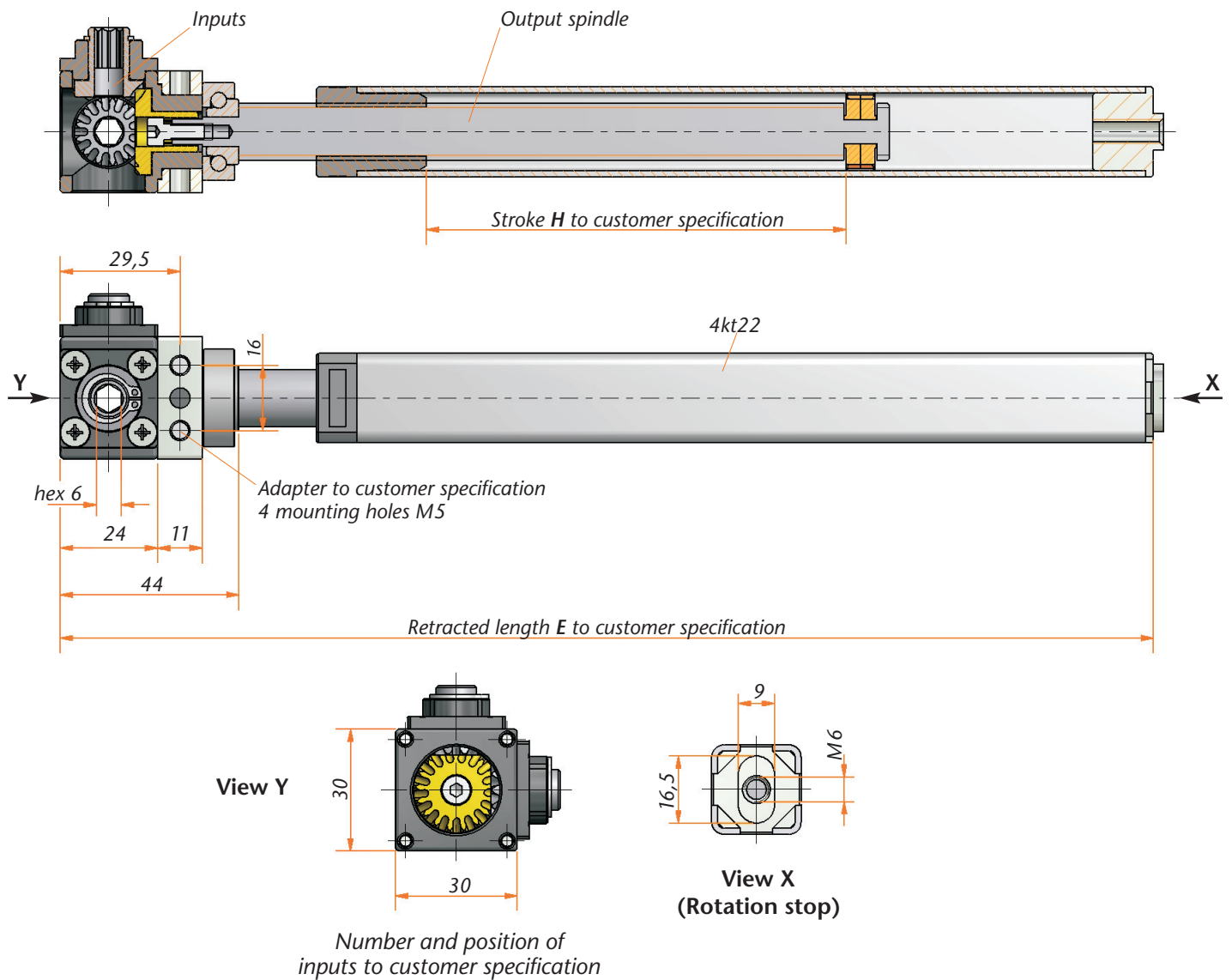

## Technical Data

Model	3010	3011
Ratio	1,33 : 1	1,33 : 1
Input	hex 6 mm	hex 6 mm
Number of inputs	max. 4	max. 4
Type of spindle	Tr14x3 right	Tr14x3 left
Stroke max.	retracted height -99mm	retracted height -99mm
Max. lifting force	1200 N	1200 N
Max. input torque	3 Nm	3 Nm