

## Bevel gear

stepless height adjustment

3 0 1 4



### Description:

Gear for stepless height adjustment, mainly for manual sit/sit work stations.

### Special features

- Ratio 1 : 1; 1 : 1,33
- Glass fibre reinforced plastic housing at angle 120° or 135°
- Hardened steel gear cogs
- 1200 N load capacity
- Output spindle for push force only

### Customer specific:

Because of the modular design it is possible to meet special customer requirements even for small quantities.

The gear is available in various lengths and with various mounting brackets.

Different input angles are available even in small quantities.

### Caution:

Please take into account that depending on the spindle pitch, the system could back-drive.

# Bevel gear 3014

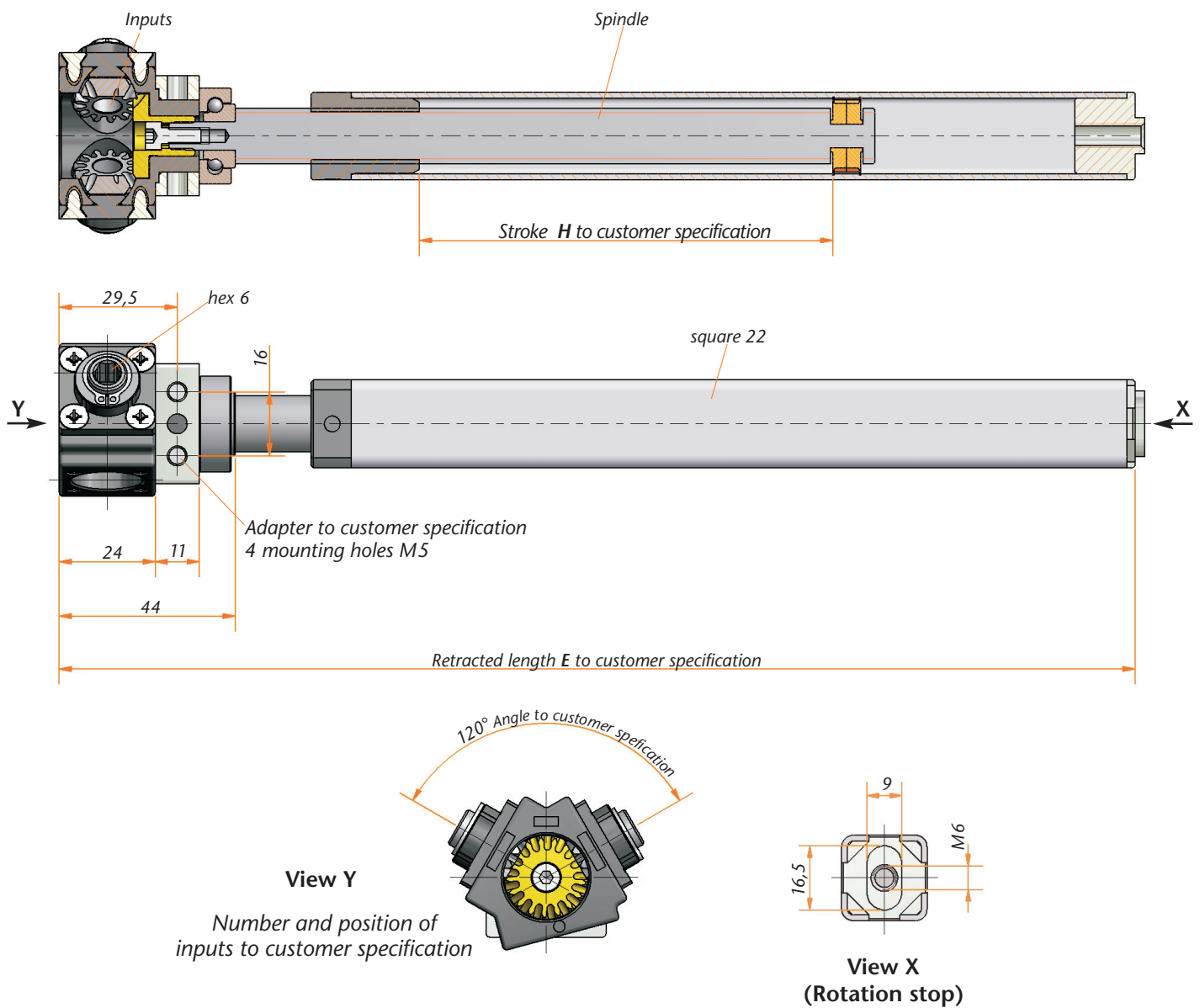

## Technical Data

Model	3014
Ratio	1 : 1 / 1,33 : 1
Input	hex 6 mm
Number of inputs	2
Type of spindle	Tr14x3 right
Stroke max.	retracted length -99 mm
Max. lifting force	1200 N
Max. input torque	3 Nm