

Bevel gear

stepless
height adjustment

3 0 5 6

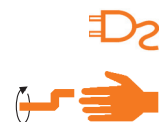

Description:

Gear for stepless height adjustment of sit/sit- or sit/stand work stations.

Special features:

The gear ratio 1:2 doubles the speed for height of sit/sit- or sit/stand work stations. The gear housing is of the cast zinc with bearing seated output spindle.

Customer specific:

The gear can be supplied with various spindle lengths and spindle pitches.

Caution:

Please take into account that depending on the spindle pitch, the system could back-drive.

Bevel gear 3056

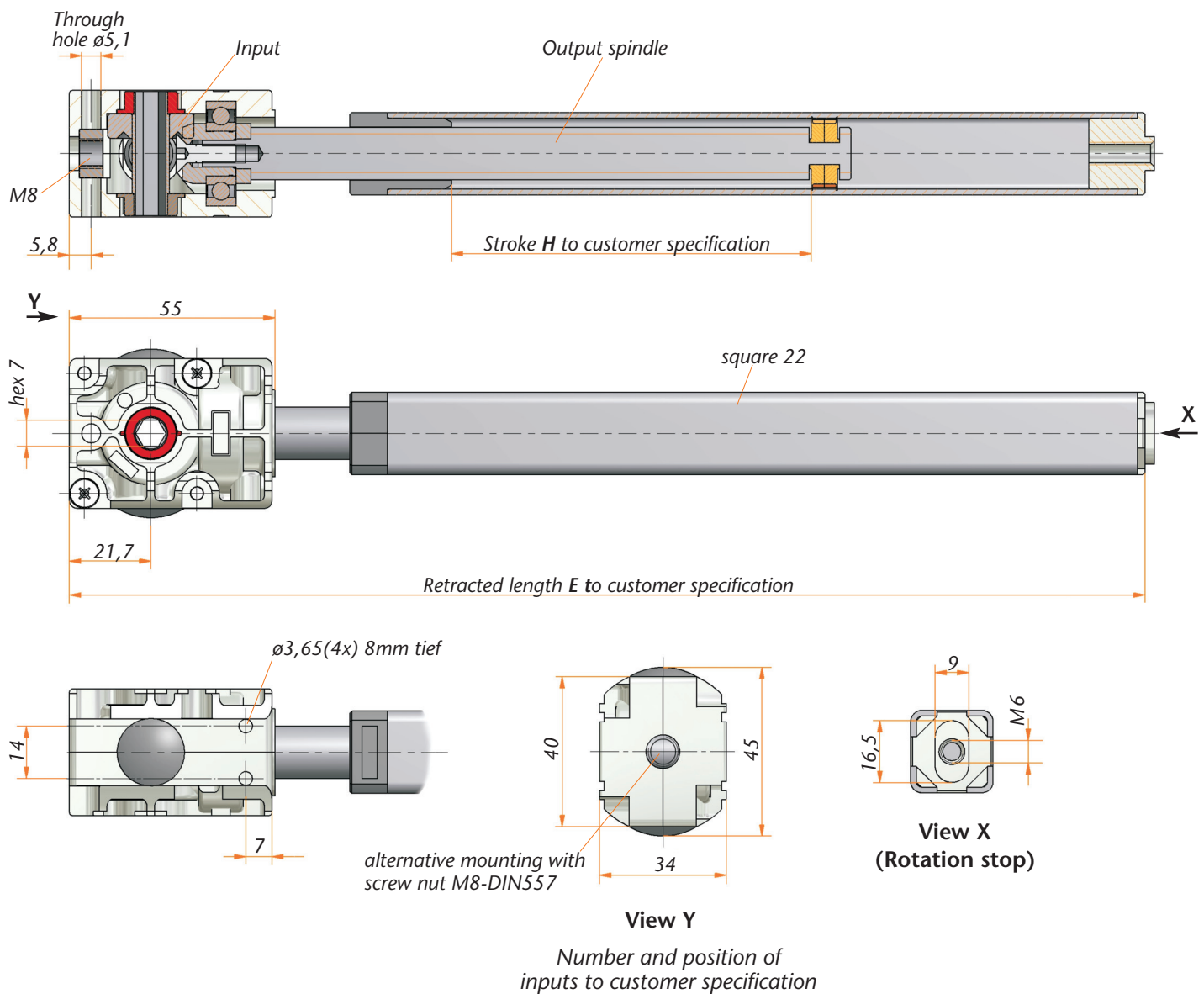

Technical Data

Model	3056
Ratio	1 : 2
Input	hex 7 mm
Type of spindle	Tr14x3 right
Stroke max.	retracted length -110 mm
Max lifting force	1200 N
Max. input torque	6 Nm