

## Motor drive



Motor drives

**KTS  
3130**



### **Description:**

Motor drive with through-going hexagon socket.

### **Special features:**

Integrated position measuring system. Simple upgrade from manual to motorized solution. The motor drive is completely damped against vibration and noise by an elastic coupling as well as by several absorbers.

### **Customer specific:**

Compact motor drive for customer specific applications. Simply adaptable by two independent mounting concepts

### **Safety information:**

See technical data sheet.

# Motor drive KTS 3130

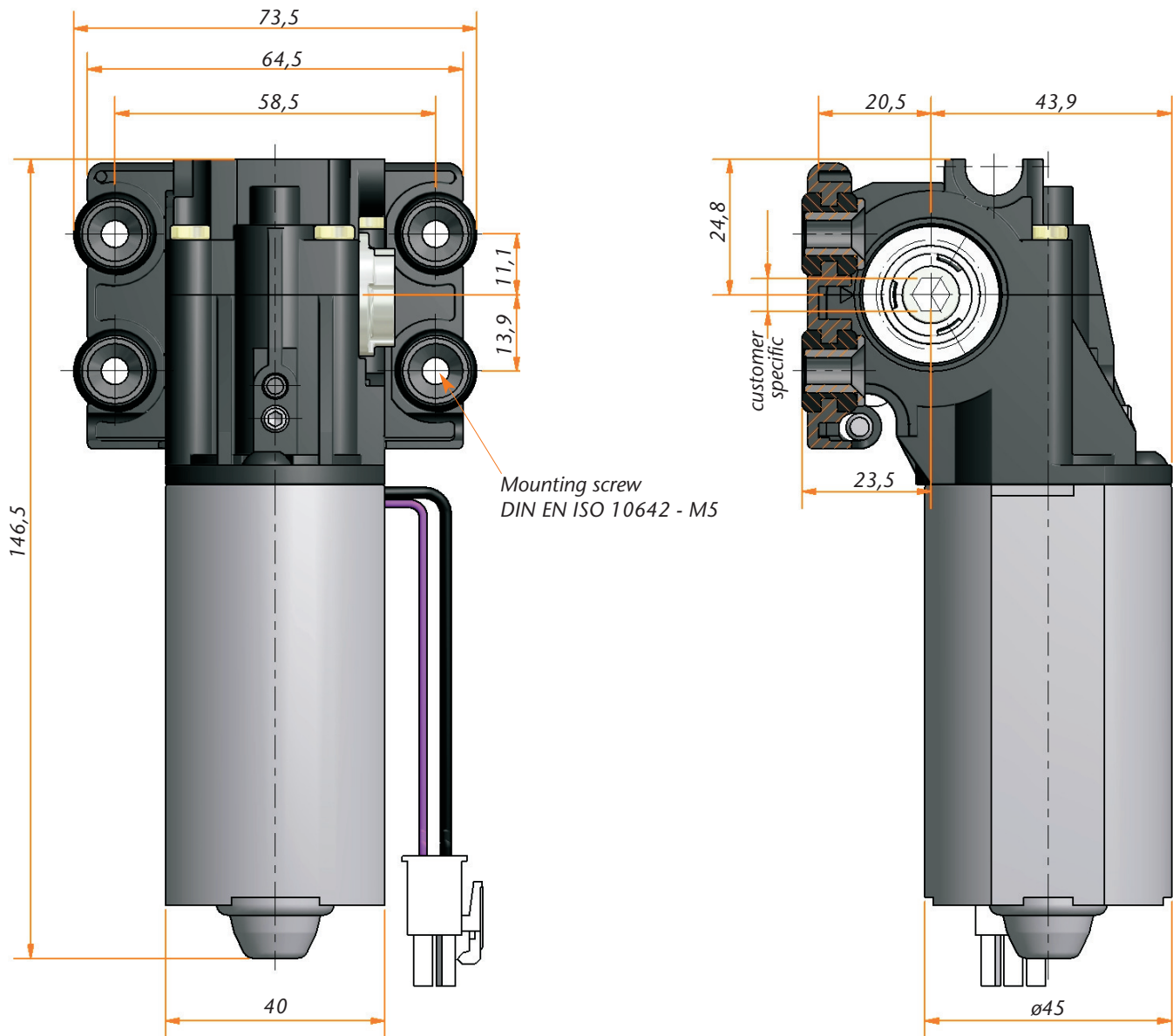

## Technical Data

| Model              | KTS 3130                    |
|--------------------|-----------------------------|
| Motor              | DC Motor 24 V               |
| Sensor-feed        | Hall/5 V DC/0,3A            |
| Type of protection | IP30                        |
| Duty cycle         | 20% (at 5 min.)             |
| Idle running speed | 150 rpm (24 V)<br>150 rpm * |
| Input              | inside hex 6/hex 7 mm       |
| Max. input torque  | 5 Nm                        |

### 2. Mounting variant

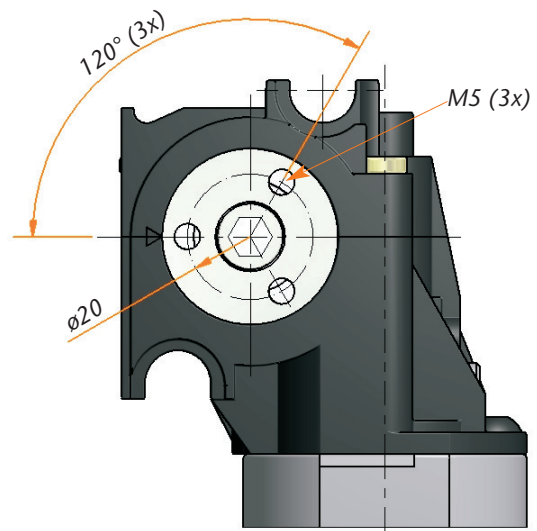

\* in combination with LogicData control Logic-S/Compact-3