

Motor drive



motor drives

KTS
3143



Description:

Hollow shaft (hex) gear motor. DC motor with worm gear.

Special features:

Actuator with integrated distance of travel output.
Simple upgrade from manual to motorized system.

Customer specific:

Compact motor drive for customer specific applications.

Safety information:

Refer to technical data sheet.

Motor drive KTS 3143 *

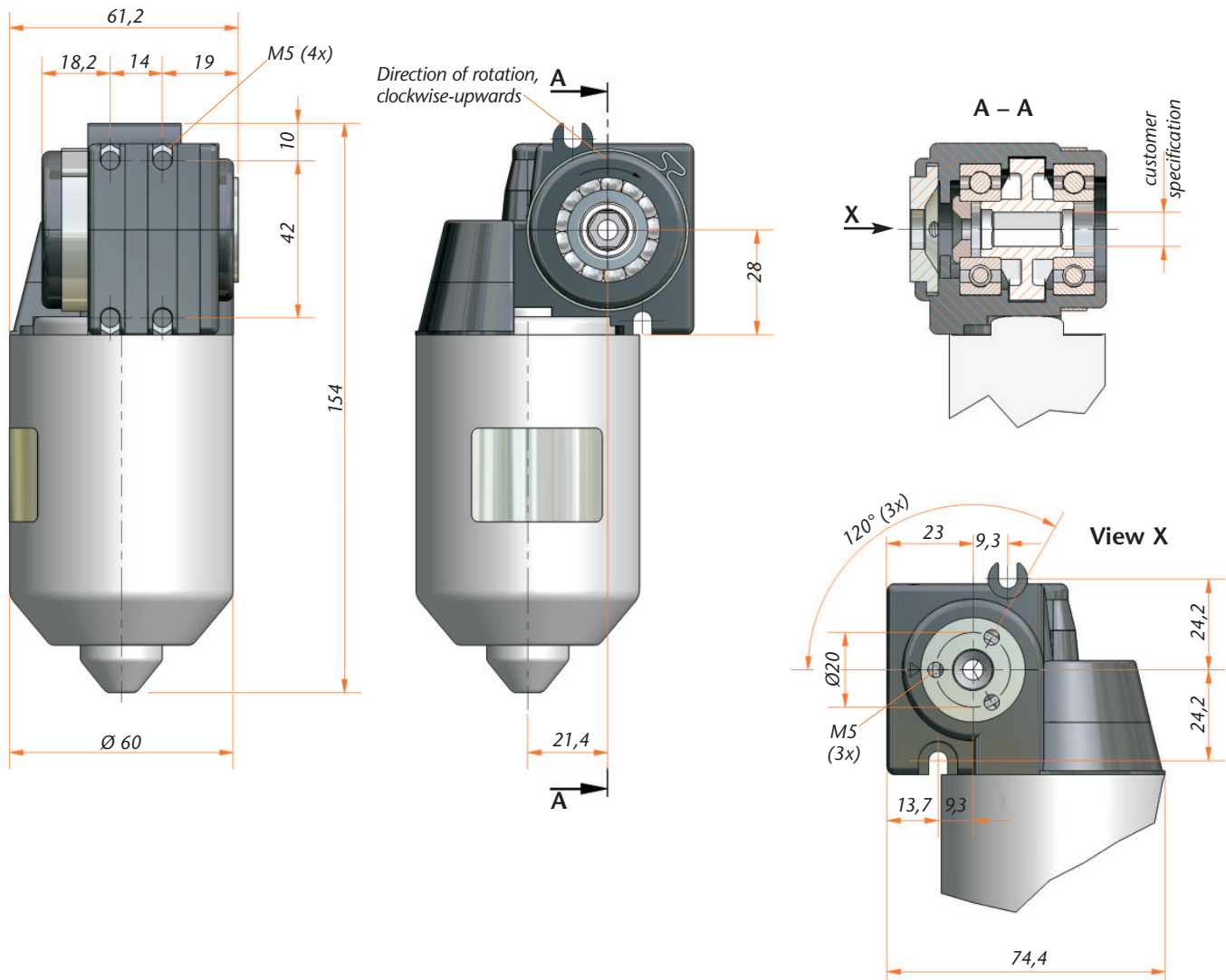

Technical Data

Model	KTS 3143
Motor	DC Motor 18 V
Sensor-feed in	Hall/5 V DC/0,3A
Electric current	average: 3,3 A at 5 Nm
Protection class/CE	IP30
Duty cycle	20% (at 5 min.)
Idle running speed	100 rpm (24 V) 150 rpm *
Input	inside hex/SW6/SW7 mm
Max. input torque	5 Nm

* in connection with control box Logic-S/Compact-3

Application example

