

## Electric linear drive with spindle



motor drives

3 1 4 6



### *Description:*

Direct current motor with worm gear and through-going not rotating spindle for push and pull movements.

### *Special features:*

Motor drive with integrated position measuring system.

### *Customer specific:*

Compact motor drive for customer specific applications. Spindle pitch can be modified to customer requirements.

### *Caution:*

Please take into account that depending on the spindle pitch, the system could back-drive.

# Electric linear drive with spindle 3146

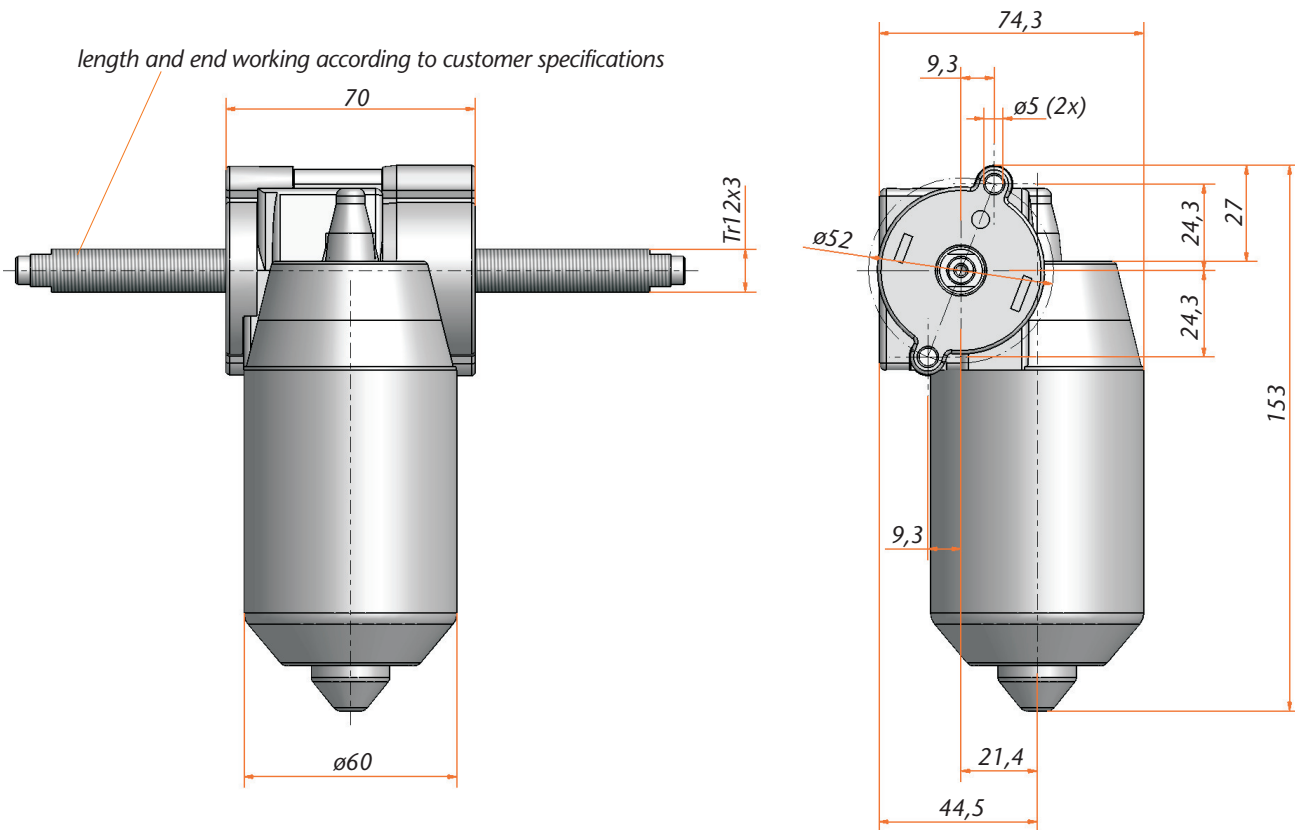

## Technical Data

| Model              | 3146                       |
|--------------------|----------------------------|
| Motor              | DC Motor 18 V              |
| Sensor-feed in     | Hall/5 V DC/0,3A           |
| Type of protection | IP30                       |
| Duty cycle         | 20% (at 5 min.)            |
| Idle running speed | 90 rpm (24 V)<br>130 rpm * |
| Type of spindle    | Tr12x3 RH                  |
| Max. input torque  | 1200 N                     |
| Speed of movement  | 4 mm/s *                   |

\* in connection with control box Logic-S/Compact-3