

Electric spindle drive

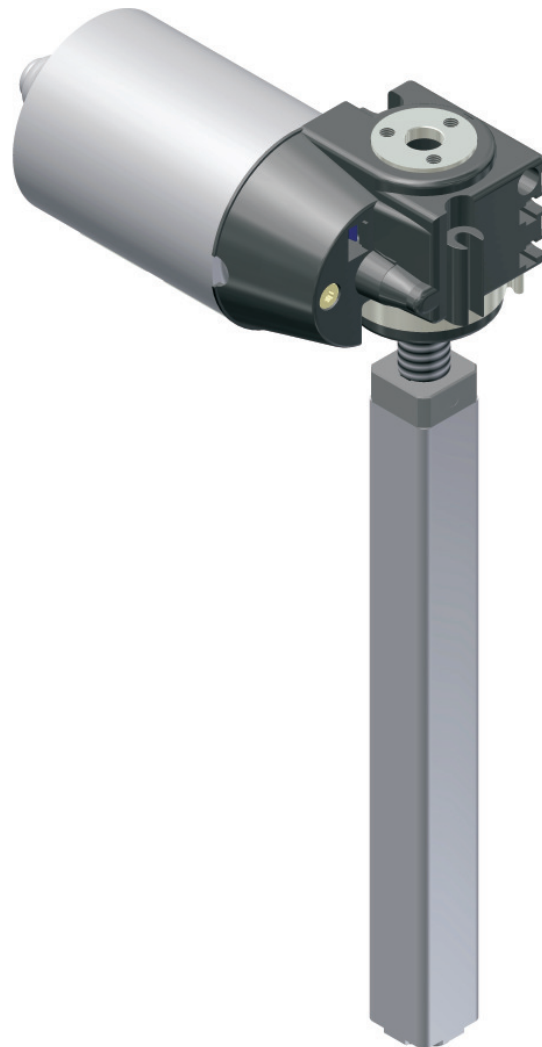

*stepless
height adjustment*

4640



Description:

Motorized solution for sit/stand workplace.
Stepless height adjustment to customer specific travel distance.

Special features:

Simple mounting, integrated distance of travel output.
Single telescopic function. Synchronization with up to 26 actuators.

Customer specific:

As a result of the drive's modular structure, special customer requirements can be met.
The drive can be supplied with different spindle lengths and different spindle pitches.

Caution:

Please take into account that depending on the spindle pitch, the system could back-drive.

Electric spindle drive 4640

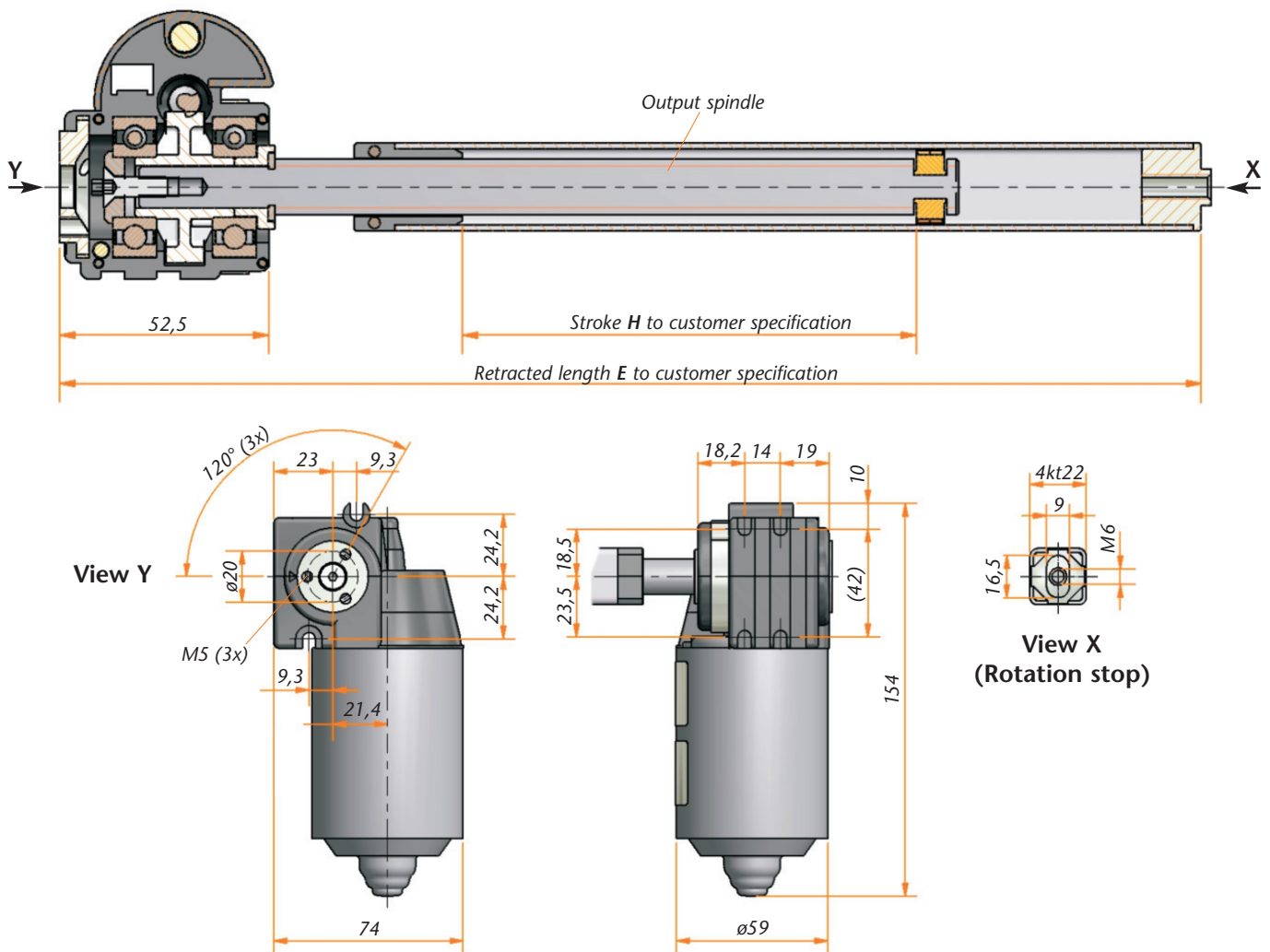

Technical Data

Model	4640.00-V01ExxxHxxx
Motor	DC Motor 24 V
Sensor-feed in	Hall/5 V DC/0,3A
Type of protection	IP30
Duty cycle	20% (at 5 min.)
Idle running speed	100 rpm (24 V) 150 rpm *
Stroke max.	retracted length -107 mm
Type of spindle	SG14x16P4 RH **
Max. lifting force	800 N
Max. input torque	5 Nm
Speed of movement	40 mm/s *

** further type of spindles on request

* in combination with LogicData control Logic-S/Compact-3

Application example

